



Mounts

O Mounts	123
P Mounts	124
Combi Mounts – Type PC	125
Sandwich Mounts	126
Machinery Isolators	127,128
Spring Mountings PSX & PSM	129
Machine Mount Type PSN	130
PAB Mounts	131

www.completerubber.com.au

'O' MOUNTS

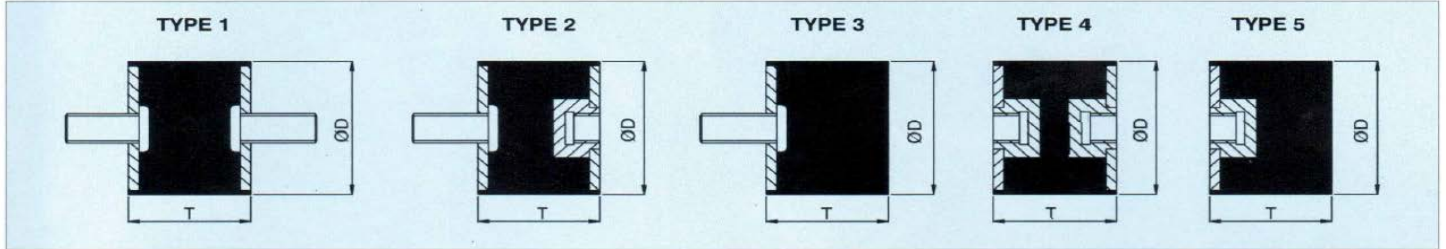

SIZE/PART No. (DXT) (mm)	MAX COMPRESSIVE LOAD (kg)	STATIC DEFL (mm)	THREAD SIZE	
			BOLT	NUT
PO 13x13	A 4.5	1.0	3/16"BSWx13L	3/16"BSWx4DEEP
PO 16x13	A 4.3	1.0	1/4"BSWx19L	1/4"BSWx4DEEP
PO 16x15	A 5.6	1.0	M5x0.8Px12L	M5x0.8Px5DEEP
PO19x19	A 18	3.0	1/4"BSWx19L	1/4"BSWx6DEEP
	B 25	3.0		
	C 35	3.0		
PO20x20	C 29	4.0	M6x1Px17L	M6x1Px6DEEP
PO25x25	A 6.0	3.0	M6x1Px17L	M6x1Px6DEEP
	B 8.0	3.0		
	C 11	3.0		
	D 18	3.0		
	E 21	3.0		
PO25x29	A 16	1.5	5/16"BSWx22L	5/16"BSWx6DEEP
	B 22	1.5		
	C 29	1.5		
	D 42	1.5		
PO25x20	A 30	3.5	M6x1Px13L	M6x1Px6DEEP
	B 45	3.5		
	C 60	3.5		
PO25x22	A 50	3.5	M8x1.25Px20L	M8x1.25Px6DEEP
PO25x30	A 37	3.0	M8x1.25Px20L	M8x1.25Px6DEEP
	B 52	3.0		
	C 73	3.0		
PO30x22	A 64	3.5	M8x1.25Px25L	M8x1.25Px25L
PO30x30	A 22	3.0	M8x1.25Px21L	M8x1.25Px6DEEP
PO35x22	A 34	3.0	3/8"BSWx38L	3/8"BSWx6DEEP
PO35x25	A 16	1.5	3/8"BSWx38L	3/8"BSWx6DEEP
	B 21	1.5		
	C 40	1.5		
	D 65	1.5		
PO38x25	A 70	4.0	M8x1.25Px17L	M8x1.25Px6DEEP
	B 110	4.0		
	C 175	4.0		
PO38x38	A 50	6.0	M8x1.25Px17L	M8x1.25Px10DEEP
	B 67	6.0		
	C 85	6.0		
PO40x28	B 146	4.5	M10x1.5Px25L	M10x1.5Px6DEEP
PO40x30	B 60	5.0	M8x1.25Px25L	M8x1.25Px6DEEP
PO40x40	A 43	6.0	M10x1.5Px38L	M10x1.5Px10DEEP
	B 59	6.0		
	C 82	6.0		

SIZE/PART No. (DXT) (mm)	MAX COMPRESSIVE LOAD (kg)	STATIC DEFL (mm)	THREAD SIZE	
			BOLT	NUT
PO50x40	A 65	5.0	M10x1.5Px22L	M10x1.5Px12DEEP
	B 110	5.0		
	C 150	5.0		
PO50x45	B 106	7.0	M10x1.5Px25L	M10x1.5Px12DEEP
PO50x50	A 76	7.0	M10x1.5Px22L	M10x1.5Px12DEEP
	B 100	7.0		
	C 120	7.0		
PO55x38	A 58	3.0	3/8"BSWx34L	3/8"BSWx10DEEP
	B 84	3.0		
	C 117	3.0		
PO60x45	A 214	8.0	M10x1.5Px19L	M10x1.5Px10DEEP
	B 311	8.0		
	C 453	8.0		
PO60x50	A 110	6.5	M12x1.75Px27L	M12x1.75Px15DEEP
	B 145	6.5		
	C 185	6.5		
PO60x60	A 110	8.0	M12x1.7Px27L	M12x1.75x15DEEP
	B 150	8.0		
	C 200	8.0		
PO63x36	A 115	5.0	1/2"BSWx33L	1/2"BSWx10DEEP
PO75x55	A 158	6.0	M12x1.75Px37L	M12x1.75Px15DEEP
	B 180	6.0		
	C 290	6.0		
PO80x60	A 300	8.0	M12x1.75Px30L	M12x1.75Px20DEEP
	B 400	8.0		
	C 520	8.0		
PO80x75	A 205	10	M12x1.75Px30L	M12x1.75Px20DEEP
	B 310	10		
	C 420	10		
PO100x55	A 320	6.0	M16x2Px30L	M12x1.75Px20DEEP
PO100x75	A 280	10	M12x1.75Px30L	M12x1.75Px20DEEP
	B 390	10		
	C 520	10		
PO100x90	A 285	12	M12x1.75Px30L	M12x1.75Px20DEEP
	B 400	12		
	C 540	12		
PO115x100	A 380	10	M14x2Px35L	M14x2Px35DEEP
	B 540	10		
	C 720	10		

METHOD OF ORDERING

PO
38
25
A
2
 D T STIFFNESS TYPE

'P' MOUNTS



APPLICATION

- For effective isolation of noise and vibration from rotating equipment with speeds of 1000 RPM and above
- Typically used to isolate fans, pumps, generators, air-conditioning units and general machinery

FEATURES

- Static deflection ranges from 5-12mm
- Colour coded load range
- Threaded top
- Non-skid ribbed base

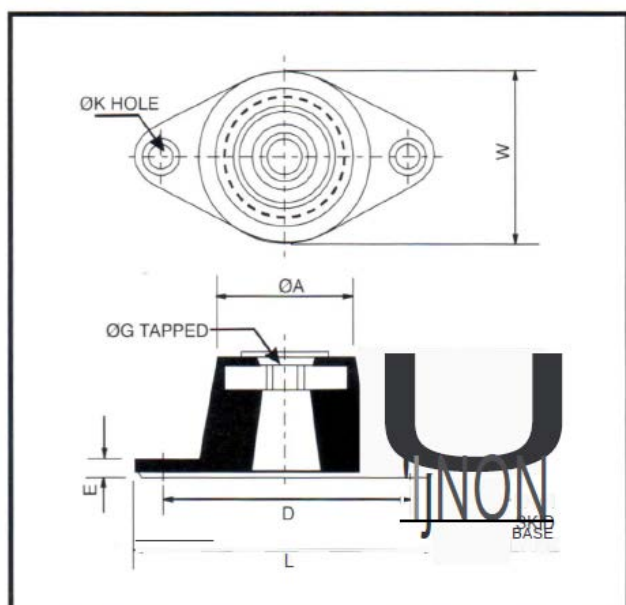

PART NO.	COLOUR CODE	MAX LOAD (kg)	STATIC DEFL. (mm)
P-1A	BLUE	15	5
P-1B	WHITE	25	
P-1C	GREEN	40	
P-1D	YELLOW	60	
P-1E	RED	80	
PD-1A	BLUE	15	8
PD-1B	WHITE	25	
PD-1C	GREEN	40	
PO-iD	YELLOW	60	
PD-1E	RED	80	
P-2A	BLUE	70	10
P-2B	WHITE	100	
P-2C	GREEN	175	
P-2D	YELLOW	250	
P-3B	WHITE	145	6
P-3C	GREEN	240	
P-3D	YELLOW	340	
P-3E	RED	500	
PD-3B	WHITE	145	12
PD-3C	GREEN	240	
PO-3D	YELLOW	340	
PD-3E	RED	500	
P-4B	WHITE	680	6
P-4C	GREEN	1020	
P-4D	YELLOW	1360	
P-4E	RED	1800	
PD-4B	WHITE	680	12
PD-4C	GREEN	1030	
PD-4D	YELLOW	1360	
PD-4E	RED	1800	

TYPE	DIMENSIONS (mm)							
	H	L	W	D	ØA	ØG	ØK	E
P-1	28	80	45	60	32	M8	8.5	5
P-2	32	98	60	76	45	M10	8.5	6
P-3	44	140	85	104	64	M12	14	6
P-4	45	165	110	127	100	M12	14	6
PD-1	35	80	45	60	32	M8	8.5	5
PD-2	44	98	60	76	45	M10	8.5	6
PD-3	72	140	85	104	64	M12	14	6
PD-4	75	165	110	127	100	M12	14	6

COMBI-MOUNTS TYPE PC



POLYBOND COMBIMOUNTS PC are suitable for a wide variety of equipment. The COMBIMOUNT PC, is low profile, compact in size and ideal for mobile application due to added 'Fail Safe' feature. These mounts can be supplied with a height adjustment feature if required.

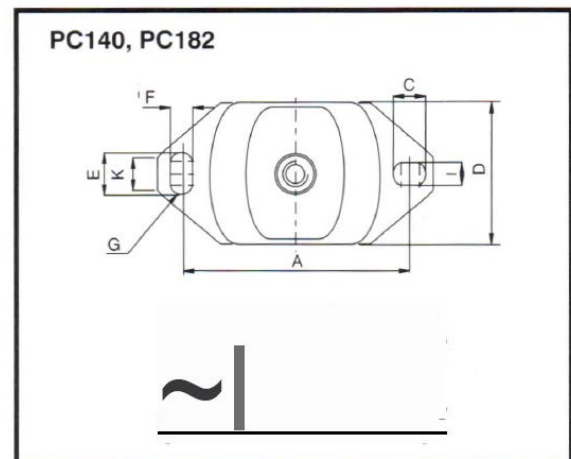
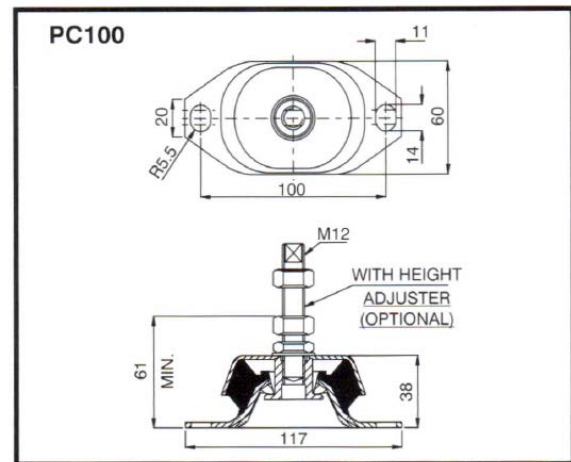

PART NO.	LOAD	DEFLECTION
PC 100	A 50	4
	B 70	
	C 100	
PC140	A 135	5
	B 200	
	C 300	
PC182	A 355	5
	B 530	
	C 800	
	D 1000	

ALL DIMENSIONS (mm)

PART NO.	DIMENSIONS (mm)										
	A	B	C	D	E	F	G	H	I	J	K
PC140	140	178	20	76	30	13	6.5	49	13	M16	25
PC182	182	220	26	112	34	18	9.0	70	18	M20	28

When placing orders please specify 'Type I' (without height adjustment feature) or 'Type II' (with height adjustment feature)

SANDWICH MOUNTS



SANDWICH mounts are designed to support heavy or sensitive equipment and isolate intermittent or continuous vibrations. These mounts can be loaded by compression of the two. The easy-to-install SANDWICH mounts result in longer service life, smoother operation and reduced maintenance.

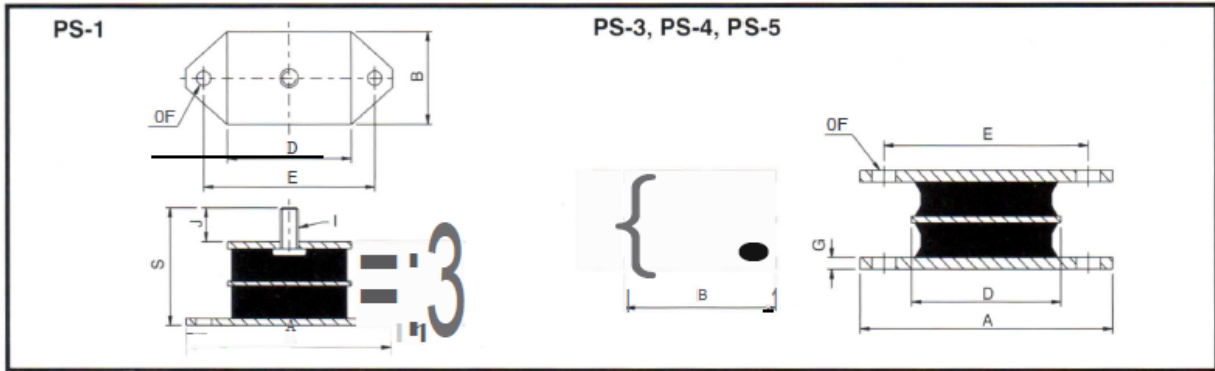

Part No	DIMENSIONS (mm)										MAX LOAD IN COMPRESSION	STATIC DEFL. (mm)
	A	B	C	D	E	F	G	H	I	J		
PS-1A											95	2.8
PS-1B											135	2.8
PS-1C	90	40	36	54	74.5	6.75	3.5	51	M8	15	200	2.8
PS-1D											310	2.8
PS-1E											350	2.4

Part No	DIMENSIONS (mm)							MAX LOAD IN COMPRESSION	STATIC DEFL (mm)
	A	B	C	D	E	F	G		
PS-3A								140	3.0
PS-3B	110	60	43	65	89	10.3	5.0	240	3.0
PS-3C								375	3.0
PS-5A								400	3.0
PS-5B								610	3.0
PS-5C	170	60	43	125	146	10.3	5.0	850	2.8
PS-5D								1000	2.2
PS-5E								1900	2.0

MACHINERY ISOLATORS

ISOLATORS

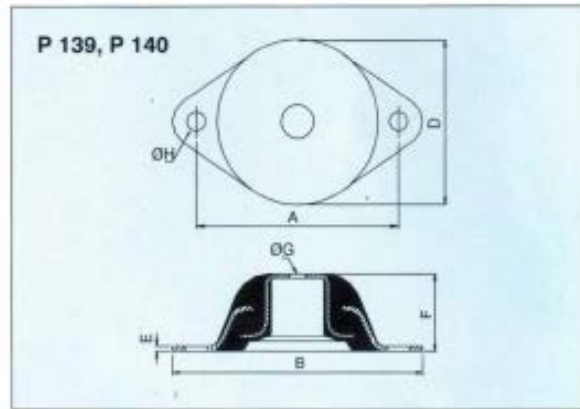
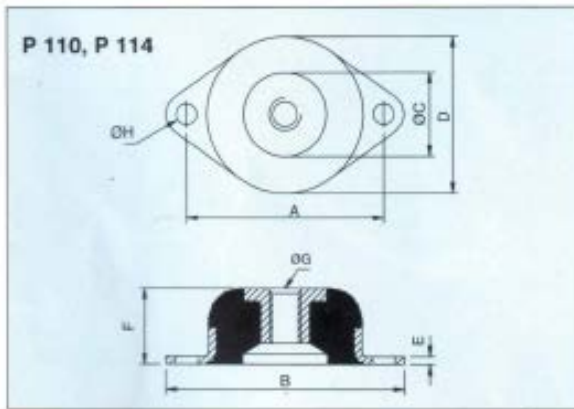
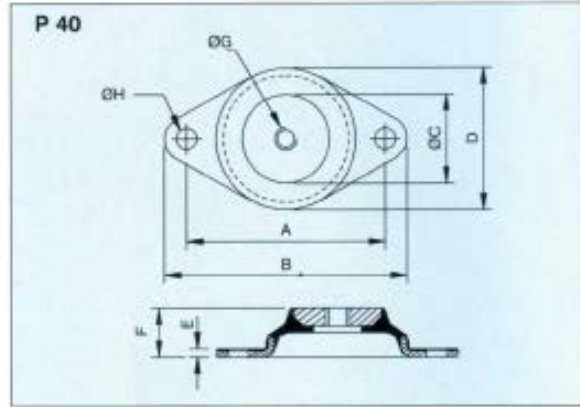

PART NO	DIMENSIONS								MAX LOAD IN COMP (kg)	DEFLECTION (mm)
	A	B	ØC	D	E	F	ØH	ØH		
P40	49.4	60	22	35	1.5	12	M6	5	45	3.0
P110A	60	76	41	48	3	22	7/16" UNF	8.7	40	3.7
P110B									55	3.5
P110C									85	3.5
P114A	76	92	59	60	3	29	1/2" UNF	8.7	60	3.6
P114B									90	3.6
P114C									130	3.5
P139A	127	157	-	105	3	48	Ø	14.2	550	4.6
P139B									725	4.5
P139C									900	4.4
P140A	110	141	-	82	2.5	41	Ø13	13.5	280	4.7
P140B									350	4.4
P140C									500	4.7
P140D									880	4.6

MACHINERY ISOLATORS

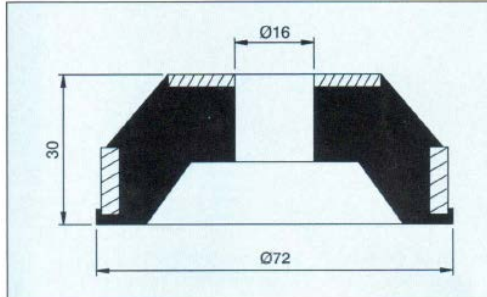

PART NO.	LOAD (kg)	DEFLECTION (mm)
P104 A	57	4
P104 B	90	4
P104 C	125	4
P104 D	180	4

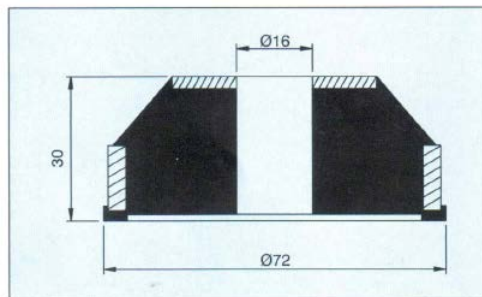

PART NO.	LOAD (kg)	DEFLECTION (mm)
P204	270	4

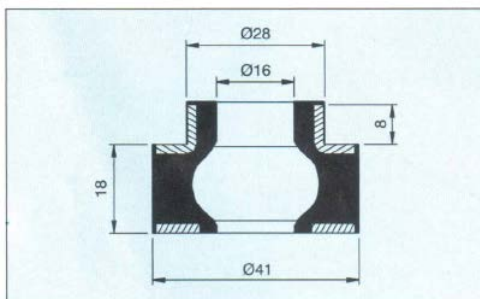

PART NO.	LOAD (kg)	DEFLECTION (mm)
P107 A	115	4
P107 B	170	4
P107 C	250	4
P107 D	280	4

ALL DIMENSIONS IN mm.

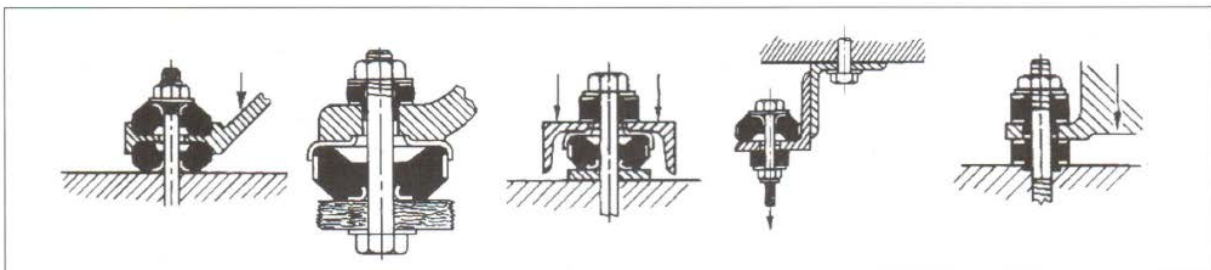

SPRING MOUNTINGS PSX & PSM

APPLICATION

- Where an inexpensive spring hanger element is required for effective vibration isolation
- Typically used to support fans, pumps, compressors and packaged air-conditioners

FEATURES

- Colour coded springs for visual identification of load range
- Heavy duty stable steel spring
- Bolt hole in base rubber isolated
- Bonded acoustic rubber pad on base type (PSX)
- Spring located by moulded rubber cup. Type (PSM)
- Built in levelling bolt and locking cap screw supplied with type PSM
- Fully weatherproofed

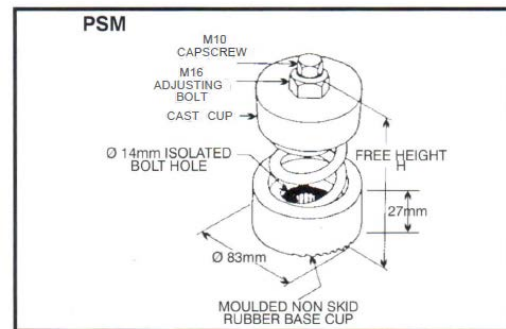
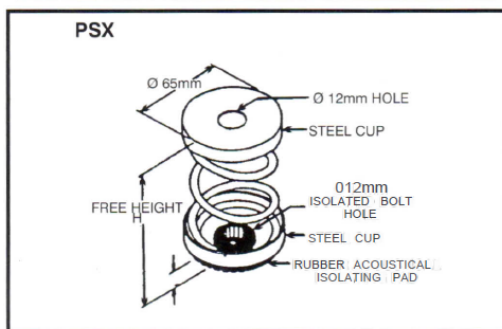

TYPE	MAX LOAD (kg)	STATIC DEFLECTION (mm)	SPRING CONST (kg/mm)	SPRING COLUR CODE		H (mm)	
				SPRING	STRIPE		
PSM	89	10	40	0.25	WHITE	-	122
	90	20	38	0.53	DARK GREY	-	122
	91	35	35	1.0	DARK GREY	WHITE	122
	92	50	33	1.5	YELLOW	-	122
	93	100	33	3.0	BROWN	-	122
	94	150	30	5.0	BLUE	-	122
	95	200	30	6.7	BLACK	-	122
	96	250	28	8.9	RED	-	122
	97	300	28	10.7	GREEN	-	122
	98	400	25	16.0	GREY	-	122
99	550	23	23.9	ORANGE	-	122	
100							
PSX	9	10	33	0.30	YELLOW	-	81
	0	15	33	0.45	BROWN	-	81
	11	30	33	0.9	BLUE	-	81
	12	50	28	1.8	BLACK	-	81
	13	75	25	3.0	RED	-	81
	14	125	25	5.0	GREEN	-	81
	16	175	20	8.8	GREY	-	81
	17	200	15	13.3	ORANGE	-	81

MACHINE MOUNT TYPE PSN



ADVANTAGES OF MACHINE MOUNT

- No foundation required, avoids expensive grouting
- Built-in levelling arrangement
- Quick installation of machinery
- Safeguards installed equipment from surroundings shocks and impacts
- Also absorbs shocks of installed equipment
- Re-arrangement of shop-Floor layout is now easy
- Keeps the machine in position firmly

POLYBOND MACHINE MOUNTS are especially suited for mounting workshop machinery without being anchored to the ground. These ready-to-install mounts allow the need for foundations or grouting. The height adjustment feature allows precise levelling of machinery. POLYBOND MACHINERY MOUNTS will provide excellent mobility of machinery layout in your workshop. These mounts will insulate high frequency vibrations and sound, and prevent wandering of machinery due to the large contact area.

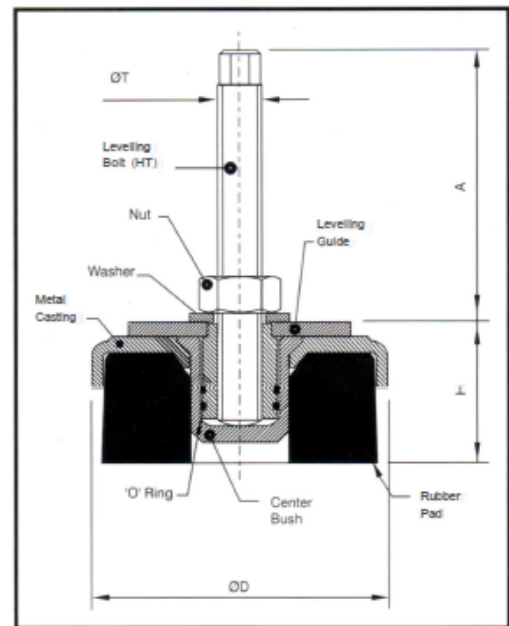

Machine Mounts	PSN-1	PSN-2	PSN-3	PSN-4
OO	80mm	120mm	160mm	200mm
H	38-50mm	46-59mm	53-68mm	63-78mm
A	87mm	79mm	122mm	122mm
OT	M12x1.25	M16x1.5	M20x1.5	M20x1.5
Optional	-	M12x1.25	M16x1.5	M16x1.5
Load Range	50-500kg	200-1100kg	800-2100kg	1500-4000kg

PAB MOUNTS

The fail safe design of this product allows the usage of these for both stationary as well as mobile applications. The horizontal stiffness is much higher than the vertical stiffness, hence these are used where there is a need to avoid the horizontal movement considerably (e.g. 'floating of machine tools')

Typically it is used for applications like motors, small generating sets, machine tools, eccentric presses. Textile machines, woodworking machines, ventilation system etc.

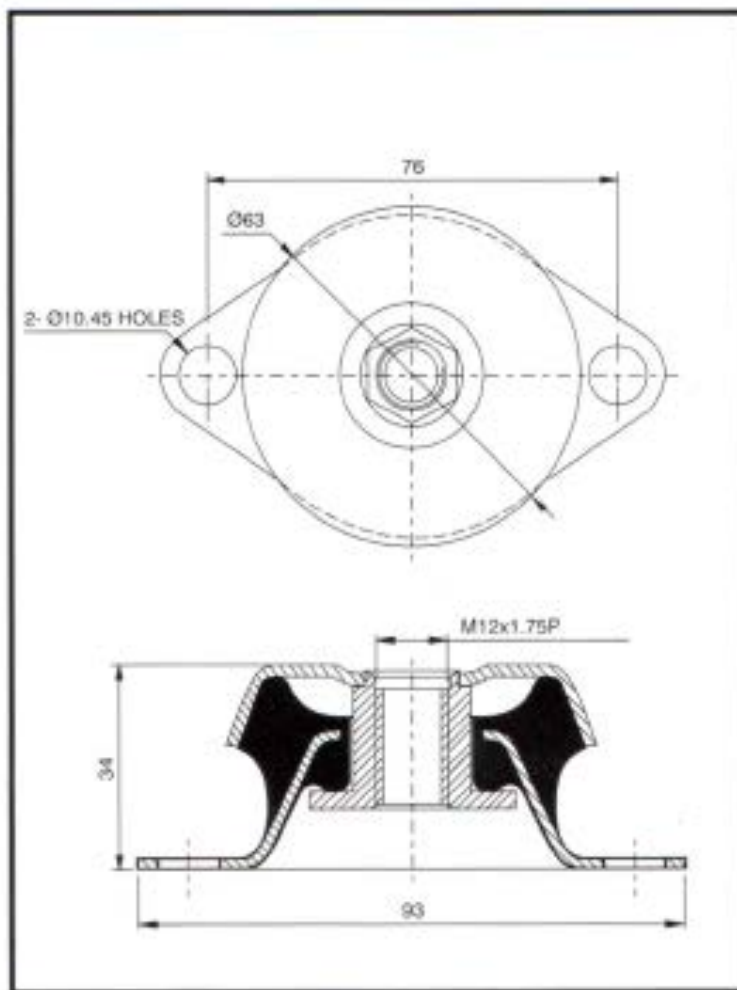

PART NO.	MAX LOAD (kg)	DEFLECTION AT MAX LOAD (mm)
PAB -1A	70	4.0
PAB-1B	105	4.0
PAB-1C	130	4.0